

# Engine Driven JumboZ-500 Hydraulic Steering System

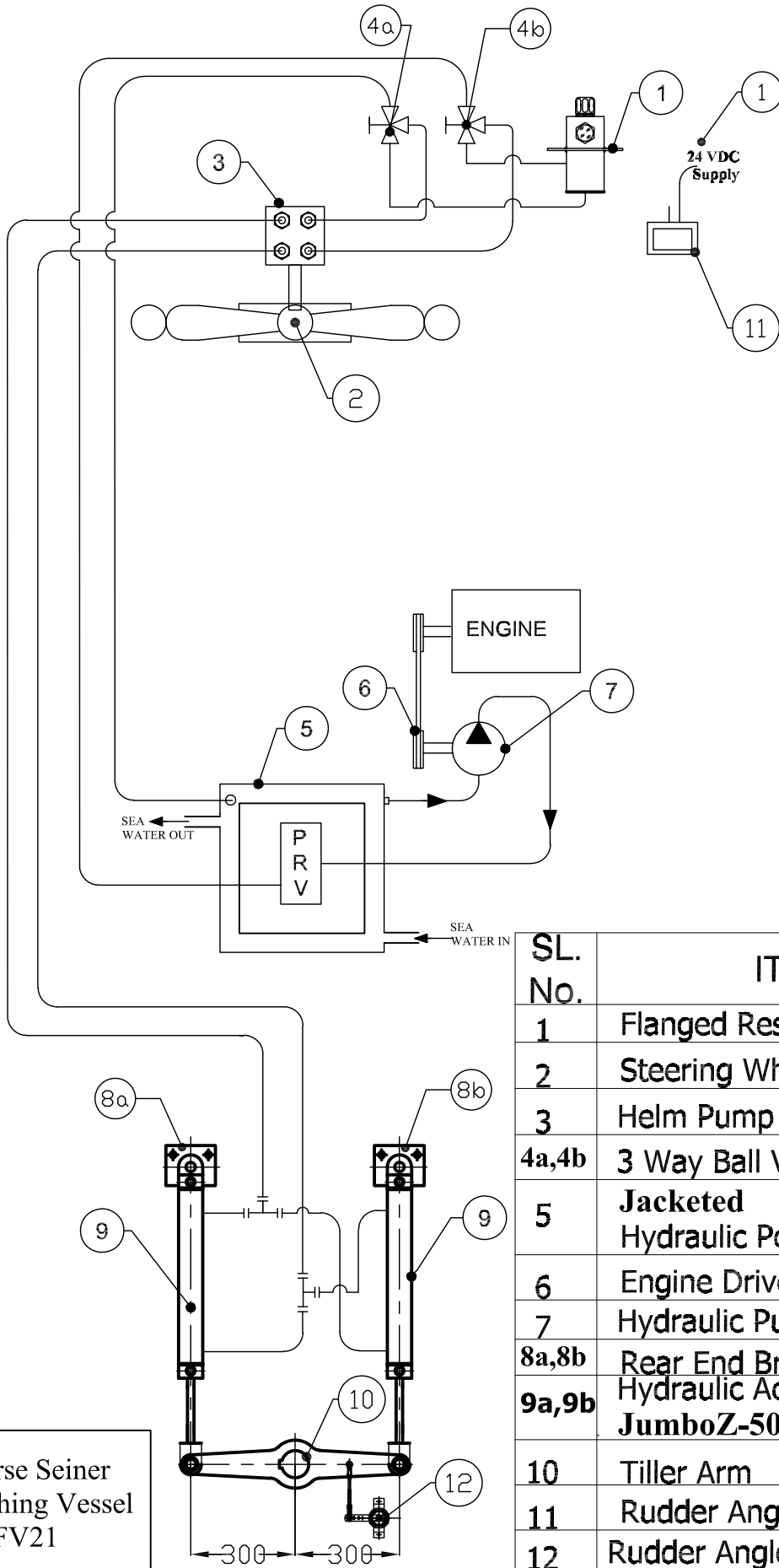

SL. No.	ITEM
1	Flanged Reservoir
2	Steering Wheel
3	Helm Pump
4a,4b	3 Way Ball Valve
5	Jacketed Hydraulic Powerpack Tank
6	Engine Driven Pulley
7	Hydraulic Pump
8a,8b	Rear End Bracket
9a,9b	Hydraulic Actuator - JumboZ-500
10	Tiller Arm
11	Rudder Angle Indicator
12	Rudder Angle Sensor

Project : Purse Seiner Fishing Vessel  
Yard No: TFV21

	<b>MAC ♦ N ♦ HOM SYSTEMS</b> <b>KOCHI - 20</b>	DESIGNATION	DWG. No.	DATE
		Hydraulic Schematic Diagram JumboZ-500 Engine Driven	MHS-1550A	07-01-2023